

EXPERIMENTAL ANALYSIS OF THE SMALL-SCALE R744 HEAT PUMP EQUIPPED WITH A TRIPLE-PASSAGE MOTIVE NOZZLE EJECTOR

Krzysztof Banasiak^(a), Armin Hafner^(b), and Trygve M. Eikevik^(c)

^(a) Silesian University of Technology,
Konarskiego 22, Gliwice 44-100, Poland, Krzysztof.Banasiak@polsl.pl

^(b) SINTEF Energy Research,
Kolbjørn Hejes v. 1D, 7465 Trondheim, Norway, Armin.Hafner@sintef.no
^(b) Norwegian University of Science and Technology,
Kolbjørn Hejes v. 1B, 7465 Trondheim, Norway, trygve.m.eikevik@ntnu.no

ABSTRACT

An experimental investigation on the optimum operation parameters for the small-scale R744 heat pump equipped with a triple-passage motive nozzle ejector was performed. Different supply configurations of the motive nozzle channels were examined, for a given geometry of the mixing section and the diffuser. The tests were performed for two independent stages, distinguished according to the conditions at the suction nozzle inlet: floating quality/superheat stage and constant superheat stage.

The tests proved that both the ejector efficiency and the overall system performance (COP) were notably dependent on the motive nozzle supply strategy. Thus, for the proposed design of the ejector, the motive nozzle feeding management may be considered one of potential control parameters for the optimization of the system operation.

1. INTRODUCTION

Applying a transcritical R744 ejector in the refrigeration system is one of the most promising methods to increase the system efficiency and reduce the throttling loss, Elbel and Hrnjak (2008), Elbel (2011). In addition, the ejector's simplicity (no moving parts) of construction compared to expanders, low cost and reasonable efficiency make it closer to practice.

In order to investigate the possibility of ejector application in domestic R744 heat pumps the prototype R744 ejector test facility was devised and manufactured at SINTEF Energi. Former investigations proved the preliminary research results were promising, Zha et al. (2007), Drescher et al. (2007), Drescher et al. (2008) and Banasiak et al. (2011) - a very good COP improvement potential for the R-744 transcritical process deploying the two-phase ejector was determined, as the pressure ratio for the compressor could be reduced. However, further work still has to be done to investigate the influence of the geometry parameters and assembly combinations to study the behavior and characteristics of the ejector. Additional improvement seems to be unquestionably possible, by the modification of geometry for different ejector passages.

Therefore, the main aim of the present paper was an experimental analysis of the R744 heat pump equipped with a novel geometry ejector with a three-passage motive nozzle, regarding the thermodynamic and hydraulic performance of the system. The influence of the motive nozzle feed strategy on the overall COP of the heat pump as well as the ejector efficiency for two alternative control strategies were examined.

2. TEST FACILITY

All of the performed experiments were carried out at the multifunctional R744 ejector test facility devised and assembled at SINTEF Energy Research. A transcritical R744 cycle consisted of the following processes (Figure 1):

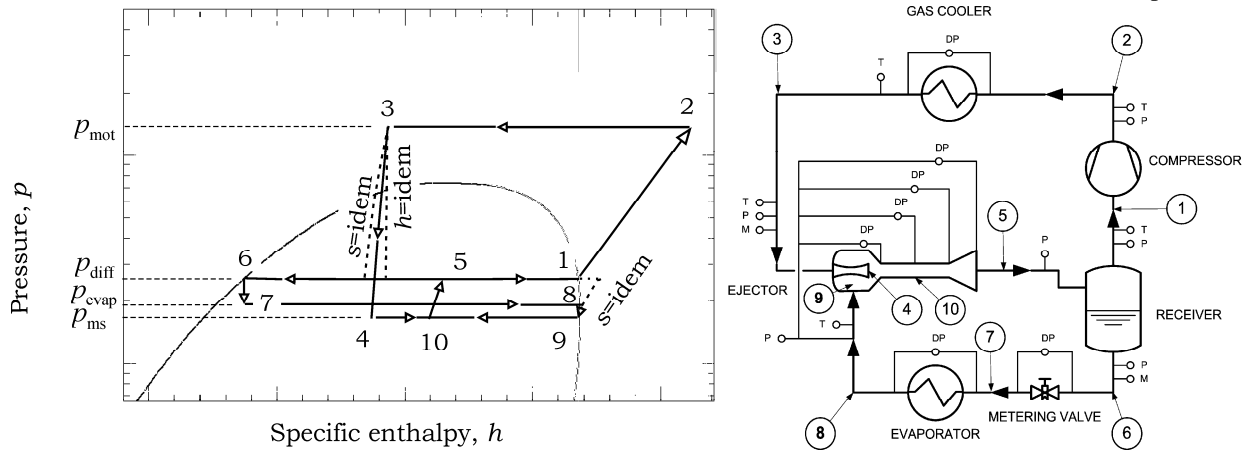

Figure 1. Scheme of a R744 transcritical cycle with a two-phase ejector for expansion work recovery. M – Coriolis-type mass flow meters, P – absolute pressure sensors, DP – differential pressure sensors, T – T-type thermocouples.

- 1-2: vapor phase compression in a piston-type compressor (variable displacement *OBRIST Engineering GmbH* C99-5 compressor with frequency controller, max. mass capacity 400 kg/h),
- 2-3: transcritical fluid cooling in a gas cooler (prototype brazed plate heat exchanger from *SWEP*),
- 3-4: expansion of the transcritical fluid in a motive nozzle (prototype three-passage manufactured by *OBRIST Engineering GmbH*, see Figure 2),
- 6-7: condensate expansion in a metering valve (*HOKE* 2300 bar stock valve with 8 ° stem point and 0.125" orifice),
- 7-8: flashing liquid evaporation in an evaporator (*KAORI* brazed plate heat exchanger model no. K040C-20C),
- 8-9: pressure drop of the vapor phase in a suction nozzle (prototype manufactured by *OBRIST Engineering GmbH*, see Figure 2),
- 4-10 and 9-10: mixing of the primary and secondary stream in a mixing chamber (prototype manufactured by *OBRIST Engineering GmbH*, see Figure 2),
- 5-10: pressure growth in a diffuser (prototype manufactured by *OBRIST Engineering GmbH*, see Figure 2),
- 5-6 and 5-1: separation of the vapor-liquid mixture in a separator (prototype design by *OBRIST Engineering GmbH*)

The measurement system was based on temperature sensors (calibrated T-type thermocouples, average uncertainty equal to ± 0.3 K), absolute and differential pressure sensors (calibrated piezoelectric elements, average uncertainty equal to ± 0.15 bar), and mass flow meters (calibrated Coriolis type, average uncertainty equal to ± 0.0005 kg/s).

The R744 two-phase ejector consisted of the motive nozzle, suction nozzle, mixing section and diffuser (see Figure 2). For the purpose of the paper analysis, constant geometry of each the constituting segment was maintained for all the experiments performed.

2.1 Triple-passage motive nozzle

The examined motive nozzle geometry consisted of three identical converging-diverging conical channels bored in the head of the main body, with symmetry lines pointed to the entry of the mixing section. The main construction parameters for each passage were as follows:

- Diameters: 3.5 mm for the inlet cross-section, 0.7 mm for the throttle cross-section and the outlet cross-section,
- Angles of tapering: 30° (half-angle) for the converging section and 0° for the diverging section,
- Wall surface roughness: ca. $1 \mu\text{m}$ according to the manufacturer data.

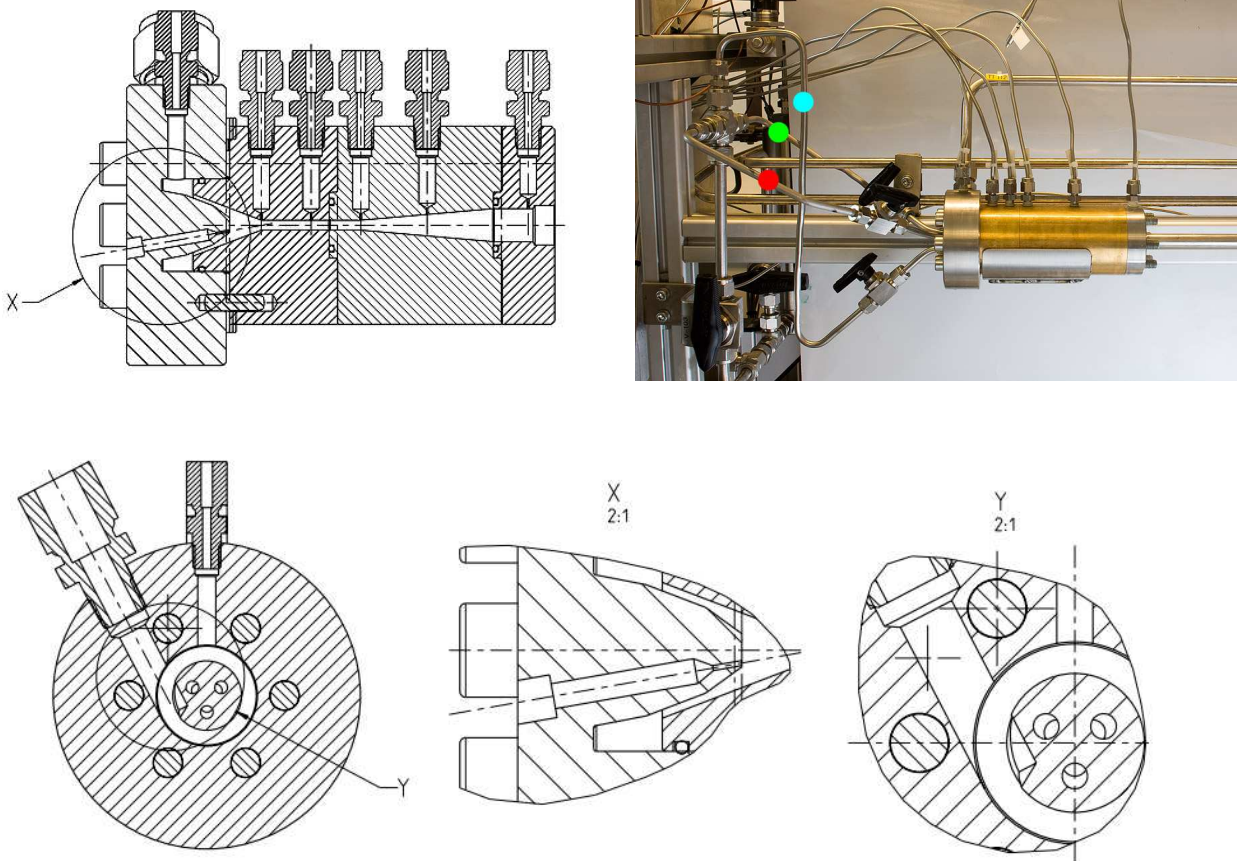

Figure 2. The ejector assembly (upper cross-section and photographic picture) and detailed geometry of the three-passage motive nozzle (lower cross-sections).

Three independent supply lines equipped with shut-off valves, one per each passage, were installed upstream the motive nozzle inlet. This manifold-like configuration enabled three feeding options: one-passage-open, two-passages-open, and three-passages-open. One of the supply lines, indicated in Figure 2 by a blue dot, due to slightly longer and more warped tubing generated higher pressure losses (and lower mass capacity) compared to the two other lines. Therefore, this line was utilized only for the three-passages-open setting.

2.2 Suction nozzle

The suction nozzle geometry was constituted by the walls of two surfaces: a conically chamfered head of the motive nozzle and a conical inlet channel to the mixing section. The cross section area of the annular suction nozzle could be adjusted by distance rings, varying the gap between the tip of the motive nozzle and the beginning of the mixing section. All of the tests reported in the paper were registered for the offset distance equal to 3.6 mm.

2.3 Mixing section

The mixing section was designed as a straight tube with a conical inlet, which in combination with the motive nozzle head created a suction nozzle. The convergence angle for the inlet cone was set for 42° , the internal diameter of the channel was equal to 3 mm, and the length of the passage was equal to 30 mm.

2.4 Diffuser

The diffuser was shaped as a conically diverging channel, where the total length of the passage was dependent on the inlet and outlet diameters and the angle of divergence. The variant selected for the tests was specified by the following parameters: angle of divergence equal to 5° , inlet diameter equal to 3 mm, outlet diameter equal to 10 mm.

3. EJECTOR PERFORMANCE INDICATORS

The key parameters for thermodynamic and hydraulic evaluation of two-phase ejectors for the expansion work recovery are the mass entrainment ratio, suction pressure ratio and ejector efficiency, Elbel and Hrnjak (2008).

The mass entrainment ratio defines the ratio between the suction mass flow rate of the ejector and the driving flow rate through the ejector motive nozzle, i.e. also called motive mass flow rate. The ejector suction pressure ratio defines the elevated pressure of the refrigerant leaving the ejector in relation to the outlet evaporating pressure. The suction pressure ratio indicates the relative pressure increase by the ejector, which is recovered.

The ejector efficiency is defined as a ratio of the amount of expansion work rate recovered by the ejector to the maximum possible expansion work rate recovery potential. The amount of expansion work rate recovered is defined as a product of the suction mass flow rate and the specific enthalpy difference, identified by points 8 and 9_s , i.e. the beginning and the end of imaginary, isentropic compression from the pressure of evaporation to the pressure of the diffuser outlet, which was replaced by the ejector (see: scheme in Figure 1). The maximum possible expansion work rate recovery potential is defined as a product of the motive mass flow rate and the specific enthalpy difference, identified by points 4_h and 4_s , i.e. at the end of theoretical, isenthalpic/isentropic expansion of the motive stream to the pressure of the diffuser outlet.

4. EXPERIMENTAL INVESTIGATION

The experimental tests were scheduled into two consecutive stages, distinguished according to the conditions at the suction nozzle inlet: floating quality/superheat stage and constant superheat stage, Jurkowski (2011).

During the first stage the heat pump capacity was regulated by adjusting the evaporation pressure with the metering valve, for several selected values of rotational speed for the compressor electric motor. The main aim at this stage was to determine the optimum evaporation pressure for the 'shut on/off' refrigeration capacity control strategy and investigate the possibility of use the motive nozzle supply options to increase the system performance.

During the second stage of the investigation the heat pump capacity was regulated by adjusting both, the rotational speed of compressor and evaporation pressure, for constant superheat at the suction nozzle inlet. The objective was to test the use of the motive nozzle supply strategy for the purpose of the performance enhancement in the systems equipped with a thermostatic expansion valve and inverter for the electric motor.

4.1 Tests at floating quality/superheat at the suction nozzle inlet

The tests were performed for the following settings of auxiliary systems: operating range of temperature for the central heating system was kept at 30/65 °C, while the water inlet temperature for the low-temperature heat source was equal to 20 °C at constant, maximum volumetric capacity of the circulation pump.

Three levels of the compressor rotational speed were selected for the analysis, namely 817 rpm, 933 rpm, and 1045 rpm. For each rotational speed level the tests were started with the metering valve at the 'full-open' position, next the valve was gradually turned down until the minimum admissible position was reached. The minimum position derived from the test facility limits, namely the minimum admissible evaporation pressure above ca. 33 bar due to the danger of ice crystals formation in the evaporator auxiliary water loop, and the maximum admissible discharge pressure below 140 bar due to the internal settings of the compressor safety system, imposed by the manufacturer. The tests results were collected in Figure 3.

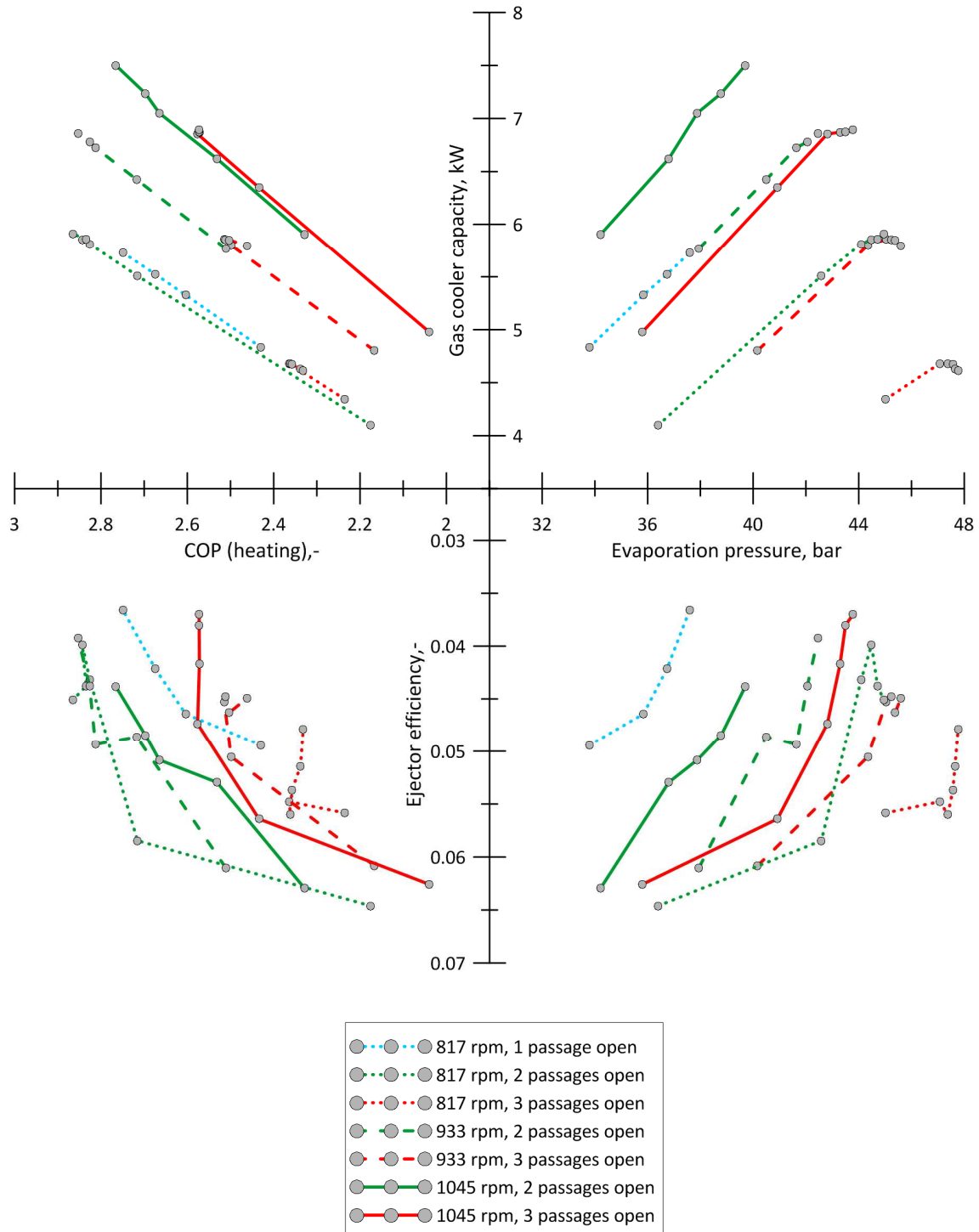

Figure 3. Relations among the heat pump performance (heating capacity and COP), ejector efficiency and evaporation pressure for floating quality/superheat at the suction nozzle inlet, for various levels of the compressor rotational speed and for all feasible supply strategies for the motive nozzle. Average values of uncertainties: ± 0.06 bar for the evaporation pressure, ± 0.004 for the ejector efficiency, ± 0.07 for COP, ± 0.09 kW for the gas cooler capacity.

According to Figure 3, influence of the evaporation pressure on the system performance was predominant (right upper quarter). Although, due to the limitations of the system configuration discussed above, each profile represents only a fragment of the whole potential operation curve, the pattern appears to be consistent and repeatable. Explicitly, lower evaporation pressure levels, at the metering valve turned down as much as admissible, lead to lower values of the heating capacity and COP mostly due to significant superheat at the evaporator outlet and deterioration of the evaporator temperature difference profile. By

reducing the pressure drop at the metering valve and lifting up the evaporation pressure (and decreasing the superheat at the same time) the heat pump performance improves (both heating capacity and COP). However, for some profiles, e.g. for the three-passages-open supply strategy, peaks in the heating capacity and COP could be noted. The authors believe they were the result of entering the two-phase area at the ejector suction nozzle inlet (see Figure 4). This meant the ejector was forced to compress not only the ‘heat-conveying’ vapor but also some ‘ballast’ liquid, sharing the recovered expansion work between the two phases. This suggests the optimum evaporation pressure for any configuration is the pressure at which saturated vapor at the suction nozzle inlet could be reached. Basically, the registered profiles depicted in Figure 4, where the COP curves were dropping right after no superheat could be detected, make that hypothesis fairly reasonable.

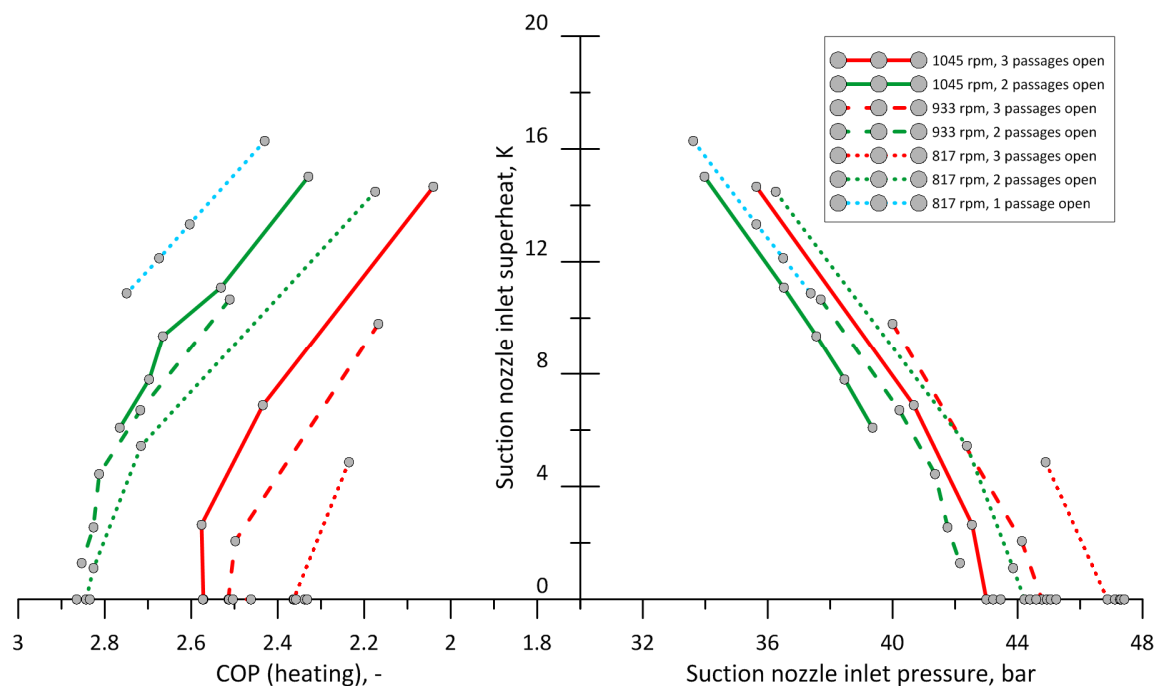

Figure 4. The suction nozzle inlet superheat as a function of the suction nozzle inlet pressure and system COP for various levels of the compressor rotational speed and for all feasible supply strategies for the motive nozzle. Average values of uncertainties: ± 0.06 bar for the suction nozzle inlet pressure, ± 0.5 K for the superheat, ± 0.07 for COP.

Considering possible use of the motive nozzle supply options to control the heat pump capacity (left upper quarter in Figure 3) it may be noticed that for each level of the compressor rotational speed the two-passages-open option outstands the other variants, offering greater capacity at higher COP at the same time, for all examined levels of the evaporation pressure. Therefore, the two-passage supply option should be considered the design configuration for the analyzed system working in the ‘shut on/off’ control regime.

The ejector efficiency proved to be growing with decreasing values of the evaporation pressure (right lower quarter in Figure 3), however only for the two-phase flow conditions at the suction nozzle inlet that growth resulted in a corresponding increase in the COP values (left lower quarter in Figure 3).

4.2 Tests at constant superheat at the suction nozzle inlet

The tests were performed for the same settings of auxiliary systems as previously, except for the water inlet temperature for the low-temperature heat source, which was decreased to 10 °C.

The heat pump capacity was altered by changing rotational speed of the compressor at a constant value of superheat, for each test point set to 5 K. Although the optimum setting of the metering valve would involve saturated vapor conditions, due to practical difficulties in detecting the precise saturation state, slight superheating was applied. The tests results were collected in Figure 5.

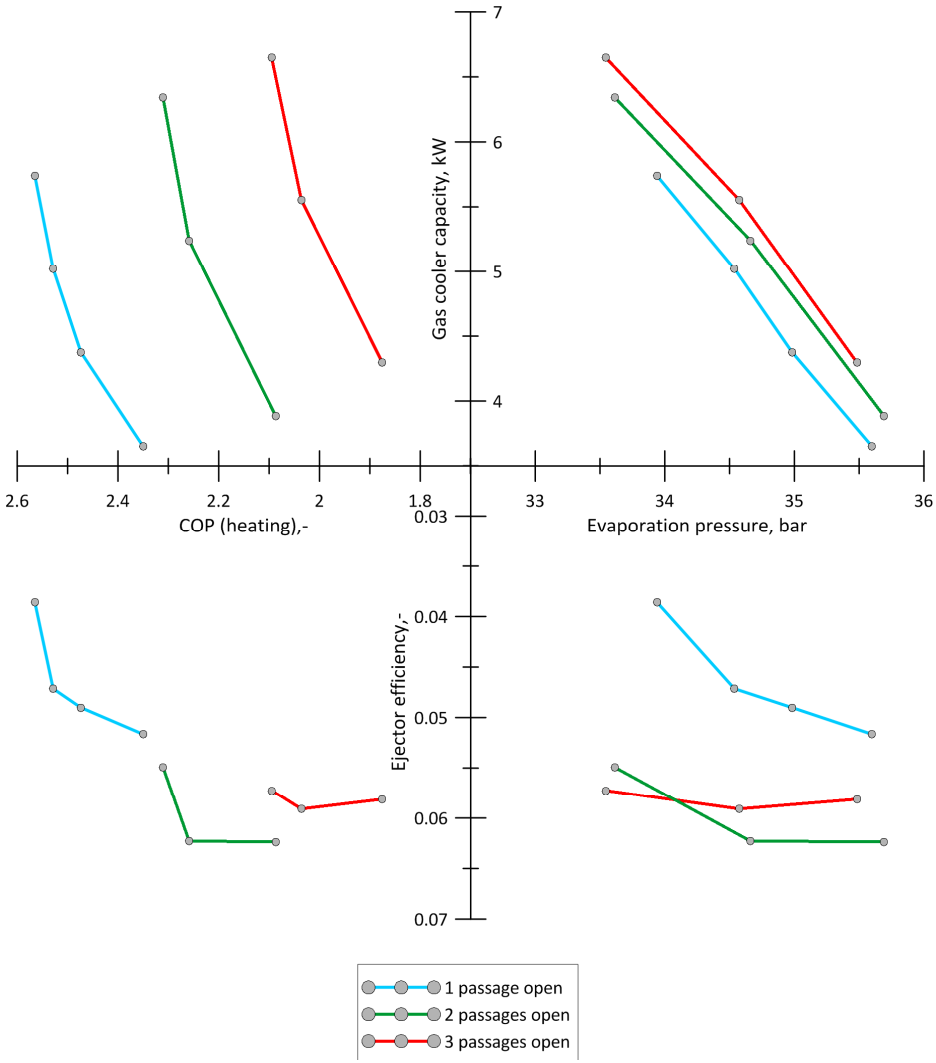

Figure 5. Relations among heat pump performance (heating capacity and COP), ejector efficiency and evaporation pressure for constant superheat at the suction nozzle inlet, for all feasible supply strategies for the motive nozzle. Average values of uncertainties: ± 0.06 bar for the evaporation pressure, ± 0.004 for the ejector efficiency, ± 0.07 for COP, ± 0.09 kW for the gas cooler capacity.

According to Figure 5, boosting the compressor rotational speed resulted in decrease of the evaporation pressure and growth of the heating capacity at the same time, for each motive nozzle supply option (right upper quarter). What is more, the system COP was also rising with the increase of rotational speed, for all supply options (left upper quarter). However, unlike at the previous stage, certain potential for utilization of the motive nozzle supply strategy might be registered. Since the most efficient supply option, for this stage the one-passage-open variant, reached its maximum capacity at 5.74 kW due to evaporation pressure dropping to the minimum admissible values, in order to further increase the heating capacity of the system it was possible to open the second passage. This would allow lifting the system output to 6.34 kW, at slightly reduced COP. Likewise, by opening the third passage it would be possible to reach 6.65 kW at the expense of further COP reduction. Therefore, the triple-passage motive nozzle could constitute a potential control mechanism for a system equipped with a thermostatic expansion valve and inverter.

The ejector efficiency proved to be generally growing with decreasing values of the system COP for each supply option (lower quarters in Figure 5), however no clear relationship between the ejector efficiency and supply option could be disclosed – the two-passages-open variant outstood the other options and reached the highest values at 6.24%.

5. CONCLUSIONS

An experimental investigation on the optimum operation conditions for the small-scale R744 heat pump equipped with a triple-passage motive nozzle ejector was executed.

The tests performed at floating quality/superheat at the suction nozzle inlet proved the influence of the evaporation pressure on the system performance was predominant and suggested the optimum evaporation pressure for any configuration was the pressure at which saturated vapor at the suction nozzle inlet could be reached. Moreover, the two-passage supply option revealed to be the optimum geometry configuration for the analyzed system working in the ‘shut on/off’ control regime.

The tests performed at constant superheat at the suction nozzle inlet revealed certain potential for utilization of the motive nozzle supply strategy. Since the lower the number of open passages the higher system COP but lower heating capacity, it is preferable to utilize first a single passage until its maximum capacity, then open the next one, etc., until the heating requirement would be fulfilled.

ACKNOWLEDGEMENTS

The research was supported by a grant from Norway through the Norwegian Financial Mechanism under the PNRF - 150 - A I – 1/07 contract and has been part of the work within the research project CREATIV, which is financially supported by the Research Council of Norway and several industry partners.

REFERENCES

- Banasiak K., Hafner A., 2011, 1D Computational model of a two-phase R744 ejector for expansion work recovery, *International Journal of Thermal Sciences* 50, 2235-2247.
- Drescher M., Hafner A., Jakobsen A., Neksa P., Zha S., 2007, Experimental Investigation of Ejector for R-744 Transcritical Systems, In: *Proc. The 22nd International Congress of Refrigeration*, Beijing.
- Drescher M., Hafner A., Banasiak K., 2008, Experimental Parameter Investigation of R744 Ejector, In: *Proceedings of 8th IIR Gustav Lorentzen Conference on Natural Working Fluids*, Copenhagen.
- Elbel S.W., Hrnjak P.S., 2008, Experimental validation of a prototype ejector designed to reduce throttling losses encountered in transcritical R744 system operation, *Int. J. Refrig.* 31, 411-422.
- Elbel S.W., 2011, Historical and present developments of ejector refrigeration systems with emphasis on transcritical carbon dioxide air-conditioning applications, *Int. J. Refrig.* 34 (7), 1545-1561.
- Jurkowski A., Experimental investigation of ejectors applied in R744 heat pumping systems, MSc Dissertation, SINTEF Trondheim, 2011.
- Zha S., Jakobsen A., Hafner A., Neksa P., 2007, Design and Parametric Investigation on Ejector for R-744 Transcritical System, In: *Proc. The 22nd International Congress of Refrigeration*, Beijing.